

Aerodynamically optimised
splitter frame



Tested to VDI 6022

Attenuators

MK

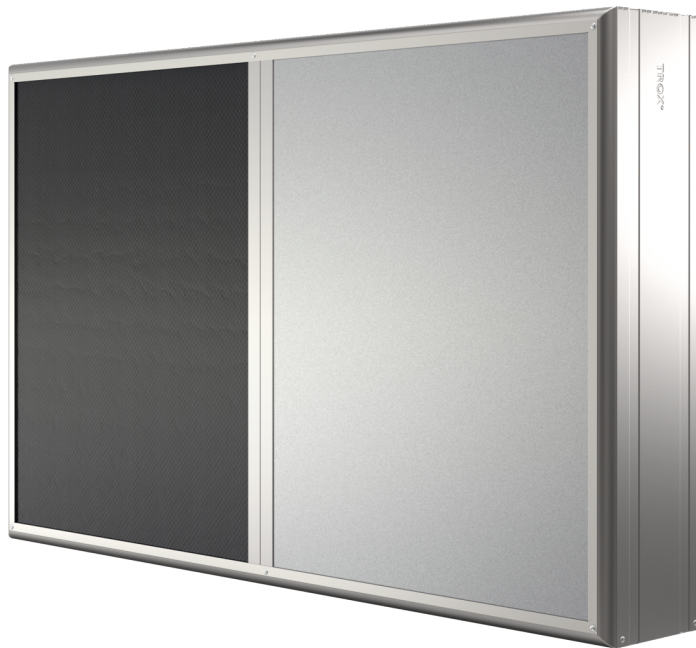

Splitter with high insertion loss and broadband attenuation even in the low frequency range

Sound attenuator splitters with resonating panels, ready to be used in ventilation and air conditioning systems

- Attenuation effect due to absorption and resonance
- Energy efficient due to aerodynamically formed frame (bullnose radius 20 mm)
- Acoustic data measured to EN ISO 7235
- Sound absorbing material is biosoluble and hence hygienically safe
- Sound absorbing material faced with glass fibre fabric as a protection against erosion due to airflow velocities up to 20 m/s
- The sound absorbing material is non-combustible, to EN 13501, fire rating class A1
- For use in areas with potentially explosive atmospheres (according to EC Directive 2014/34/EU (ATEX)), zones 1, 2, and zones 21 and 22 (outside) according to EC Directive 1999/92/EC
- Operating temperature up to 100 °C, with expanded metal (variant L) up to 300 °C for a limited period of time

Optional equipment and accessories

- Expanded metal as an additional mechanical protection for the sound absorbing material
- Stainless steel variant A2 (1.4301), with optional perforated metal facing as an additional protection for the sound absorbing material
- Other stainless steel and aluminium variants as well as PUR coating are upon request
- U-sheets and clamp sheets to join subdivided attenuator splitters

General information	2	Dimensions	9
Function	3	Weights	9
Technical data	5	Installation details	14
Quick sizing	5	Accessories – variant ACC	16
Specification text	7	Explanation	18
Order code	8		

General information

Application

- Sound attenuator splitters with resonating panels are used for the reduction of fan and air-regenerated noise in ventilation and air conditioning systems
- Attenuation effect due to absorption and resonance
- Broadband attenuation even in the low frequency range of critical fan noise
- Hygiene tested and compliant with VDI 6022
- For use in areas with potentially explosive atmospheres (EC Directive 2014/34/EU (ATEX)), zones 1, 2, 21 and 22 (outside) according to Directive 1999/92/EC

Special characteristics

Resonating panels ensure increased insertion loss in the frequency range of critical fan noise

- Energy savings due to aerodynamically formed splitter frame
 - Up to 30 % lower differential pressure
- Hygiene tested and compliant with VDI 6022
- Multi-section construction available for large dimensions

Nominal sizes

- H: 150 – 2500 mm
- L: 500, 750, 1000, 1250, 1500, 1750, 2000, 2250, 2500 mm
- Intermediate sizes of H and L are possible: 150 – 2500 mm in increments of 1 mm
- Undivided construction: H + L 600 mm min., 4000 mm max., 100 kg max.
 - Dependency for H and L: If one dimension is greater than 1500 mm, the other one must not exceed 1500 mm
- Height or length subdivided in case of a deviation, and for sizes 2501 – 5000 mm
 - Height subdivided from H ≥ 2501 mm, otherwise length subdivided

Variants

- MK100: splitter thickness 100 mm
- MK200: splitter thickness 200 mm
- MK230: splitter thickness 230 mm

Construction

Half of the splitter is covered by a resonator plate

- F: Glass fibre fabric
- L: Glass fibre fabric faced with expanded metal cover for additional mechanical protection of the sound absorbing material

Materials and surfaces

- No entry: galvanised steel 1.0917
- A2: stainless steel 1.4301
 - Construction L: Glass fibre fabric with perforated metal facing for additional mechanical protection of the sound absorbing material
- P1: powder-coated, RAL 7001, silver grey

Parts and characteristics

- Aerodynamically profiled frame
 - Reduced weight and increased rigidity due to special profile
 - Helps to optimise the airflow, hence reducing the air-regenerated noise
 - Reduces the pressure loss
 - Covers the edges of the sound absorbing material
- Absorption material and resonating panels fitted to reduce air-regenerated noise by absorption and resonance

Accessories

- U-sheets/clamp sheets to join subdivided attenuator splitters (included with subdivided splitter constructions)

Construction features

- Aerodynamically formed splitter frame (bullnose radius 20 mm) that helps to reduce turbulence on both the upstream and downstream sides; frame with grooves for increased rigidity
- Frame edges with bullnose to protect the infill
- Operating temperature up to 100 °C; variant L up to 300 °C for 8h max.

Material and surfaces

- Splitter frame, centre mullion and resonating panels made of galvanised sheet steel 1.0917 or stainless steel 1.4301
- Expanded metal cover made of galvanised steel 1.0917
- Perforated metal facing made of stainless steel 1.4301
- Sound absorbing material mineral wool
 - According to EN 13501, fire rating class A1, non-combustible
 - RAL quality mark RAL-GZ 388
 - Non-hazardous thanks to high biosolubility according to the German Ordinance on Hazardous Substances and Note Q of the European Regulation (EC) No. 1272/2008
 - Faced with glass fibre fabric, as a protection against erosion from airflow velocities of up to 20 m/s
 - Inert to fungal and bacterial growth according to EN 846

Standards and guidelines

- Insertion loss and sound power level of air-regenerated noise tested to ISO 7235
- Meets the hygiene requirements of VDI 6022, VDI 3803 Part 1 and DIN 1946 Part 4
- EC Directive 2014/34/EC (ATEX): Equipment and protective systems intended for use in areas with potentially explosive atmospheres
- EC Directive 1999/92/EC (ATEX): Improvement of the safety and health protection of workers potentially at risk from explosive atmospheres.

Maintenance

- Low-maintenance as construction and materials are not subject to wear

Function

The attenuation effect of the MK splitters is due to absorption and resonance. The splitters have a mineral wool infill as sound absorbing material. Part of the splitter surface that runs parallel to the airflow is covered with resonating panels. These panels start oscillating due to the sound (resonance) and hence absorb sound energy. Resonance works best in the frequency range of critical fan noise. There is a higher attenuation across a wider frequency range when compared to mere absorption splitters.

Schematic illustration of MK100

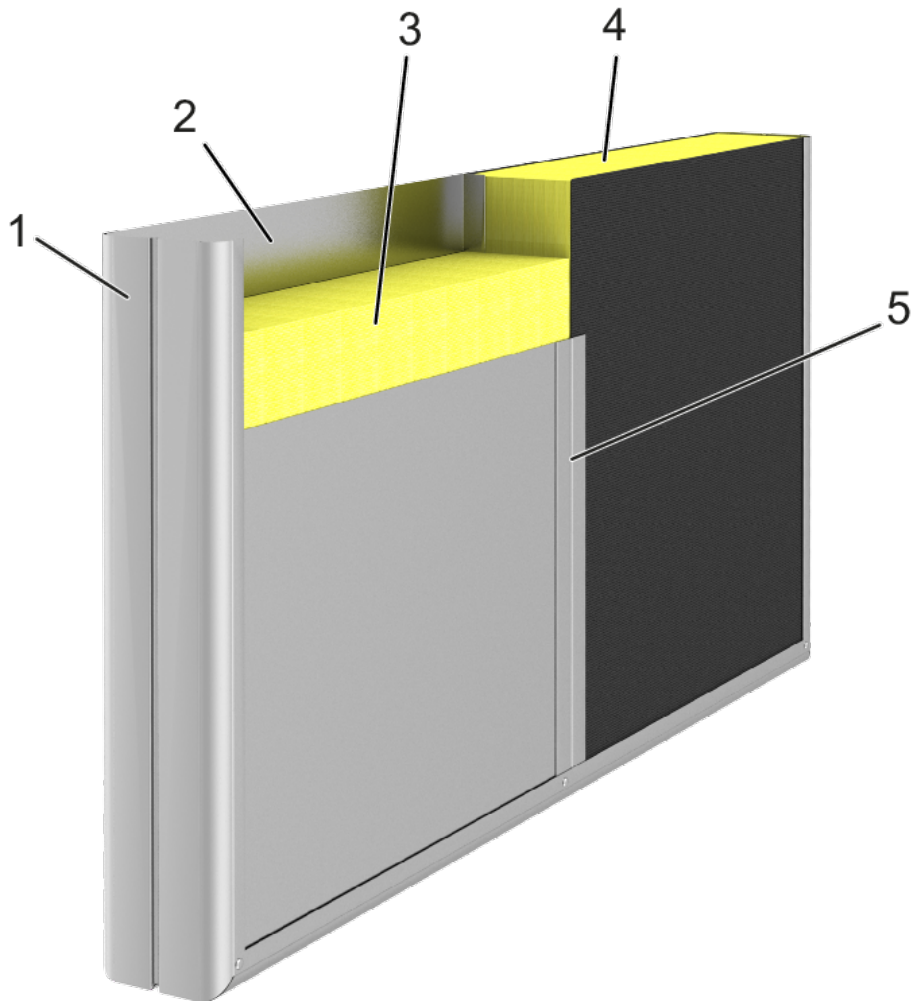

- 1 Splitter frame
- 2 Opposing resonating panels
- 3 Sound absorbing material
- 4 Sound absorbing material faced on both sides with glass fibre fabric
- 5 Centre mullion

Schematic illustration of types MK 200, 230

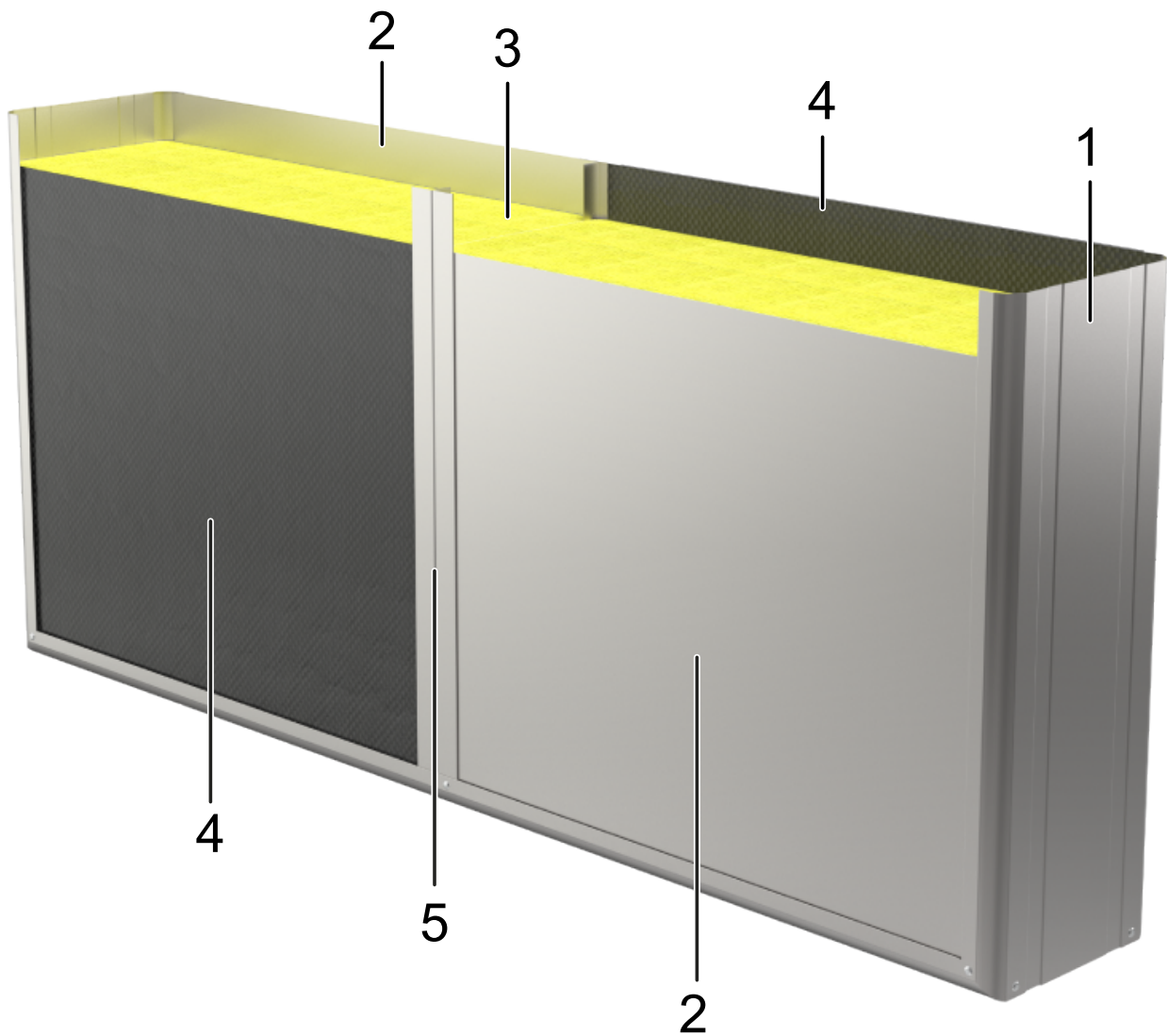

- 1 Splitter frame
- 2 Offset resonating panels
- 3 Sound absorbing material
- 4 Glass fibre fabric (facing)
- 5 Centre mullion

Technical data

Splitter thickness	100, 200, 230 mm
Nominal sizes (H × L)	150 × 450 – 1500 × 2500 mm, 450 × 150 – 2500 × 1500 mm
Height subdivide	2501 – 5000 mm or if H and L > 1500 mm
Length subdivided	2501 – 5000 mm or if H and L > 1500 mm
Intermediate sizes	In increments of 1 mm
Operating temperature	Up to 100 °C, variant L up to 300 °C for 8 h max.

The length (L) of sound attenuator splitters refers to the airflow direction.

Quick sizing

Quick sizing tables provide a good overview of the insertion loss and of differential pressures for different airway widths and airflow velocities. Intermediate values can be calculated with our Easy Product Finder design program.

The differential pressures apply to sound attenuators with a height of 1 m.

MK100, MS100, insertion loss D_e [dB] and differential pressure Δp_t [Pa]

L	Airway width	Centre frequency f_m [Hz]								v_s [m/s]		
		63	125	250	500	1000	2000	4000	8000	6	10	14
500	50	4	9	10	11	19	25	21	16	10	29	56
500	100	3	4	5	8	13	15	11	8	8	23	45
1000	50	5	11	18	20	28	34	28	23	13	37	72
1000	80	4	8	12	16	23	25	19	15	10	28	55
1000	100	4	7	9	13	21	21	15	11	9	26	51
1500	50	6	14	26	29	37	42	36	29	16	44	87
1500	80	5	11	18	22	32	32	24	19	12	32	63
1500	100	4	9	14	19	29	28	19	13	10	29	56
2000	50	7	17	34	38	46	> 50	44	36	19	52	102
2000	80	6	14	24	29	40	40	29	23	13	36	70
2000	100	5	12	19	24	37	34	22	16	11	32	62
2500	50	8	20	42	47	> 50	> 50	> 50	43	22	60	118
2500	80	7	16	30	35	48	47	34	27	14	40	78
2500	100	6	15	24	30	44	41	26	19	12	34	67
3000	50	9	22	50	> 50	> 50	> 50	> 50	50	24	68	133
3000	80	8	19	35	42	> 50	> 50	39	31	16	44	85
3000	100	7	17	28	35	> 50	47	30	22	13	37	73

MK200, MS200, insertion loss D_e [dB] and differential pressure Δp_t [Pa]

L	Airway width	Centre frequency f_m [Hz]								v_s [m/s]		
		63	125	250	500	1000	2000	4000	8000	6	10	14
500	50	4	6	18	21	24	18	15	13	21	58	114
500	100	2	4	12	13	15	12	10	8	11	31	61
1000	50	6	13	29	34	39	29	20	17	24	67	131
1000	80	5	11	24	26	29	22	16	13	15	43	84
1000	100	4	9	21	22	24	19	13	11	13	35	69
1500	50	8	20	41	46	> 50	41	26	21	27	75	147
1500	80	6	16	33	36	40	30	20	16	17	48	94
1500	100	5	14	30	32	34	25	17	14	14	40	78
2000	50	10	28	> 50	> 50	> 50	> 50	31	26	30	83	164
2000	80	8	22	43	47	> 50	39	24	19	19	53	105
2000	100	7	20	38	41	43	32	21	17	16	44	86
2000	200	3	12	23	22	18	12	10	7	9	25	50
2500	50	13	35	> 50	> 50	> 50	> 50	37	30	33	92	180
2500	80	10	28	> 50	> 50	> 50	47	28	23	21	59	115
2500	100	8	25	47	50	> 50	39	24	19	17	48	94
2500	200	4	14	29	28	22	14	11	8	10	28	54
3000	50	15	42	> 50	> 50	> 50	> 50	42	34	36	100	197
3000	80	11	34	> 50	> 50	> 50	> 50	33	26	23	64	126
3000	100	10	30	> 50	> 50	> 50	46	28	22	19	53	103
3000	200	5	17	35	34	26	16	13	10	11	30	59

MK230, MS230, insertion loss D_e [dB] and differential pressure Δp_t [Pa]

L	Airway width	Centre frequency f_m [Hz]								v_s [m/s]		
		63	125	250	500	1000	2000	4000	8000	6	10	14
500	80	2	6	14	16	18	14	12	12	15	43	84
500	100	2	5	12	13	15	11	10	11	13	35	69
1000	80	6	11	24	25	29	21	15	15	18	49	97
1000	100	5	10	21	22	25	17	13	14	14	40	78
1000	200	2	7	14	12	10	6	7	9	8	23	44
1500	80	9	17	34	35	41	28	19	18	20	56	109
1500	100	8	15	31	31	34	23	16	16	16	45	88
1500	200	3	11	20	17	14	9	10	10	9	25	49
2000	80	13	22	44	45	> 50	34	22	22	22	62	121
2000	100	11	20	40	39	44	29	20	19	18	50	98
2000	200	4	14	26	23	18	12	12	12	10	28	54
2500	80	16	27	> 50	> 50	> 50	41	25	25	25	68	134
2500	100	13	25	49	48	> 50	35	23	22	20	55	108
2500	200	5	18	33	28	22	15	15	13	11	30	59
3000	80	19	33	> 50	> 50	> 50	48	29	28	27	74	146
3000	100	16	30	> 50	> 50	> 50	41	26	25	22	60	117
3000	200	6	21	39	34	26	17	17	15	12	33	64

Specification text

This specification text describes the general properties of the product. Texts for variants can be generated with our Easy Product Finder design program.

Sound attenuator splitters used for the reduction of fan noise and air-regenerated noise in air conditioning systems. Attenuation effect due to absorption and resonance. Energy-saving as well as hygiene tested.

Installation kit consists of an aerodynamically profiled frame (bullnose radius of 20 mm), sound absorbing material and resonating panels.

The splitter frame reduces pressure losses and air-regenerated noise. The special profile helps to reduce the weight and increase the rigidity of the splitters. Frame edges with bullnose to protect the sound absorbing infill.

Insertion loss and sound power level of the air-regenerated noise tested to ISO 7235.

Meets the hygiene requirements of VDI 6022, VDI 3803 Part 1 and DIN 1946 Part 4.

For use in areas with potentially explosive atmospheres (ATEX), zones 1, 2, 21 and 22 (outside) according to Directive 1999/92/EC.

Special characteristics

Resonating panels ensure increased insertion loss in the frequency range of critical fan noise

- Energy savings due to aerodynamically formed splitter frame
 - Up to 30 % lower differential pressure
- Hygiene tested and compliant with VDI 6022
- Multi-section construction available for large dimensions

Material and surfaces

- Splitter frame, centre mullion and resonating panels made of galvanised sheet steel 1.0917 or stainless steel 1.4301
- Expanded metal cover made of galvanised steel 1.0917
- Perforated metal facing made of stainless steel 1.4301
- Sound absorbing material mineral wool
 - According to EN 13501, fire rating class A1, non-combustible
 - RAL quality mark RAL-GZ 388

- Non-hazardous thanks to high biosolubility according to the German Ordinance on Hazardous Substances and Note Q of the European Regulation (EC) No. 1272/2008
- Faced with glass fibre fabric, as a protection against erosion from airflow velocities of up to 20 m/s
- Inert to fungal and bacterial growth according to EN 846

Construction

Half of the splitter is covered by a resonator plate

- F: Glass fibre fabric
- L: Glass fibre fabric faced with expanded metal cover for additional mechanical protection of the sound absorbing material

Materials and surfaces

- No entry: galvanised steel 1.0917
- A2: stainless steel 1.4301
 - Construction L: Glass fibre fabric with perforated metal facing for additional mechanical protection of the sound absorbing material
- P1: powder-coated, RAL 7001, silver grey

Technical data

- Splitter thickness: 100, 200, 230 mm
- Dimensions: 150 × 450 – 1500 × 2500 mm, 450 × 150 – 2500 × 1500 mm
- Height subdivided: up to 5000 mm
- Length subdivided: up to 5000 mm
- Intermediate sizes: in increments of 1 mm
- Operating temperature: up to 100 °C, variant L up to 300 °C for 8 h max.

The length (L) of splitter sound attenuators refers to the airflow direction.

- B [mm]
- H [mm]
- L (in airflow direction) [mm]
- q_v (m³/h)
- D_e At 250 Hz [dB]
- Δp_{st} [Pa]

Order code

MK - ... - F - A2 / 200 × 600 × 1500

1	2	3	4	5	6	7

1 Type**MK** Sound attenuator splitter with resonating panels**2 Variant**

No entry: TROX standard variants

3 Splitter surface**F** Glass fibre fabric**L** Glass fibre fabric and expanded metal**4 Material**

No entry: galvanised steel (1.0917)

A2 Stainless steel (1.4301)**P1** powder-coated, RAL 7001 (silver grey)**5 Splitter thickness [mm]****100, 200, 230****6 Height [mm]****150 – 5000****7 Length in airflow direction [mm]****150 – 5000****Order example: MK-F-A2/100×1500×1000****Splitter surface**

Glass fibre fabric

Material

Stainless steel 1.4301

Splitter thickness

100 mm

Height

1500 mm

Length

1000 mm

Assembly material SDK**To be ordered separately if splitters are to be subdivided by others.**

SDK – A2 / 200 / 2

1	2	3	4

1 Type**SDK** Accessories for splitters**2 Material**

No entry: galvanised steel (1.0917)

A2 Stainless steel (1.4301)**P1** Galvanised steel (1.0917) and powder-coated, RAL 7001 (silver grey)**3 Splitter thickness T [mm]****100** contains 2 U-sheets**200** contains 2 U-sheets**230** contains 2 U-sheets**300** contains 2 U-sheets**4 Number of clamping plates for connection point**

No entry: without clamping plates (for H or L ≤ 750 mm)

2 for H or L 751 - 1000 mm**4** for H or L ≥ 1001 mm**Order example: SDK-A2/200/2****Material**

Stainless steel (1.4301)

Splitter thickness

200 mm, with 2 U-sheets

No. of clamp sheets

2



Dimensions

Weights

MK 100 – Glass fibre fabric (-F)

H	L									
	500	750	1000	1250	1500	1750	2000	2250	2500	
500	3	5	6	7	8	10	11	12	13	
750	5	6	8	9	11	13	15	16	18	
1000	6	8	10	12	15	17	19	21	23	
1250	7	9	12	15	18	20	23	27	30	
1500	8	11	15	18	21	24	29	32	35	
1750	10	13	17	20	24	X	X	X	X	
2000	11	15	19	23	27	X	X	X	X	
2250	12	17	21	25	30	X	X	X	X	
2500	13	18	23	28	32	X	X	X	X	

X = subdivided construction

MK 100 – Glass fibre fabric and expanded metal (-L)

H	L									
	500	750	1000	1250	1500	1750	2000	2250	2500	
500	4	5	7	8	10	12	13	15	16	
750	5	8	10	12	14	16	18	20	22	
1000	7	10	12	15	19	21	24	26	29	
1250	8	12	15	19	22	26	29	34	37	
1500	10	14	18	22	26	30	36	40	44	
1750	12	16	21	26	30	X	X	X	X	
2000	13	19	24	29	34	X	X	X	X	
2250	15	21	26	32	38	X	X	X	X	
2500	16	23	29	35	41	X	X	X	X	

X = subdivided construction

MK 100 – Glass fibre fabric and perforated sheet metal (-L-A2)

H	L									
	500	750	1000	1250	1500	1750	2000	2250	2500	
500	5	7	8	10	12	14	16	18	20	
750	7	9	12	14	17	20	23	25	28	
1000	8	12	15	18	23	26	30	33	36	
1250	10	14	18	24	28	32	36	42	46	
1500	12	17	23	28	33	38	45	50	55	
1750	14	20	26	32	38	X	X	X	X	
2000	16	23	30	36	43	X	X	X	X	
2250	18	25	33	40	48	X	X	X	X	
2500	20	28	36	44	52	X	X	X	X	

X = subdivided construction

MK 200 – Glass fibre fabric (-F)

H	L									
	500	750	1000	1250	1500	1750	2000	2250	2500	
500	5	7	9	11	13	15	17	18	20	
750	7	10	12	14	17	20	23	25	28	
1000	9	12	15	18	23	26	29	32	35	
1250	11	14	18	23	27	31	35	41	45	
1500	13	17	22	27	32	36	43	48	52	
1750	15	20	26	31	36	X	X	X	X	
2000	17	23	29	35	41	X	X	X	X	
2250	19	25	32	39	45	X	X	X	X	
2500	21	28	35	42	50	X	X	X	X	

X = subdivided construction

**MK 200 – Glass fibre fabric and expanded metal (-L)**

H	L									
	500	750	1000	1250	1500	1750	2000	2250	2500	
500	6	8	10	12	14	17	19	21	23	
750	8	11	14	17	20	23	26	29	32	
1000	10	14	17	21	26	30	34	37	41	
1250	12	17	21	27	32	36	41	48	52	
1500	14	20	26	31	37	43	51	56	61	
1750	17	24	30	36	43	X	X	X	X	
2000	19	26	34	41	48	X	X	X	X	
2250	21	29	37	45	53	X	X	X	X	
2500	24	32	41	50	59	X	X	X	X	

X = subdivided construction

MK 200 – Glass fibre fabric and perforated sheet metal (-L-A2)

H	L									
	500	750	1000	1250	1500	1750	2000	2250	2500	
500	7	9	12	14	16	19	22	24	27	
750	9	13	16	19	23	27	31	34	38	
1000	12	16	21	25	31	35	40	44	48	
1250	14	19	25	31	37	43	48	56	61	
1500	16	23	30	37	43	50	59	66	72	
1750	20	27	35	43	50	X	X	X	X	
2000	22	31	40	48	57	X	X	X	X	
2250	25	34	44	54	63	X	X	X	X	
2500	27	38	48	59	70	X	X	X	X	

X = subdivided construction

**MK 230 – Glass fibre fabric (-F)**

H	L									
	500	750	1000	1250	1500	1750	2000	2250	2500	
500	6	8	10	12	14	16	18	20	22	
750	8	11	13	16	19	22	25	28	30	
1000	10	13	17	20	25	28	32	35	39	
1250	12	16	20	25	30	34	39	45	49	
1500	14	19	25	30	35	40	48	53	57	
1750	17	23	28	34	40	X	X	X	X	
2000	19	25	32	39	45	X	X	X	X	
2250	21	28	35	43	50	X	X	X	X	
2500	23	31	39	47	55	X	X	X	X	

X = subdivided construction

MK 230 – Glass fibre fabric and expanded metal (-L)

H	L									
	500	750	1000	1250	1500	1750	2000	2250	2500	
500	6	9	11	13	16	18	21	23	25	
750	9	12	15	18	21	25	28	32	35	
1000	11	15	19	23	29	33	37	41	45	
1250	13	18	23	29	34	40	44	52	56	
1500	16	21	28	34	40	46	55	61	66	
1750	19	26	33	40	46	X	X	X	X	
2000	21	29	37	44	52	X	X	X	X	
2250	23	32	41	49	58	X	X	X	X	
2500	26	35	45	54	64	X	X	X	X	

X = subdivided construction



MK 230 – Glass fibre fabric and perforated sheet metal (-L-A2)

H	L									
	500	750	1000	1250	1500	1750	2000	2250	2500	
500	7	10	13	15	18	21	24	26	29	
750	10	14	17	21	25	29	33	37	40	
1000	13	17	22	27	33	38	43	47	52	
1250	15	21	27	34	40	46	52	60	66	
1500	18	25	33	40	47	54	64	70	77	
1750	21	30	38	46	54	X	X	X	X	
2000	24	33	43	52	61	X	X	X	X	
2250	27	37	47	58	68	X	X	X	X	
2500	29	41	52	63	75	X	X	X	X	

X = subdivided construction

Installation details

Installation and commissioning

- Follow the installation manual and comply with the general codes of good practice in order to achieve the given performance data
- Up to height H = 1200 mm, length L = 1500 mm and 40 kg: any installation orientation, but we recommend upright installation of splitters
- From height H = 1201 mm: upright installation only
- The length (L) of sound attenuator splitters and splitter sound attenuators refers to the airflow direction; be sure to note how width, height and length are defined, particularly in case of a vertical airflow
- A turbulent airflow may cause damage to the splitters
 - A straight upstream section is required upstream of the sound attenuator
 - The recommended minimum upstream section depends on the change of direction, change of cross-section and splitter arrangement
- Installation in ducts outside closed rooms requires sufficient protection against the effects of weather

Upstream conditions after bends, junctions or a narrowing or widening of the duct, vertical upstream section, splitters upright

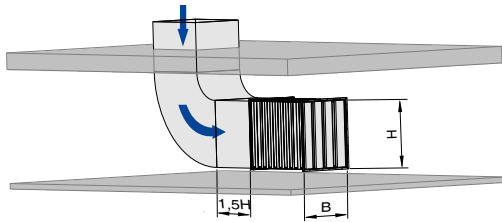

B Width of the sound attenuator
H Height of the sound attenuator and the splitters

Upstream conditions after bends, junctions or a narrowing or widening of the duct, vertical upstream section, splitters lying flat

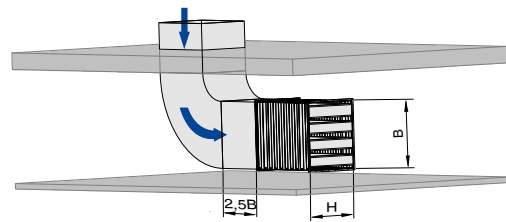

B Width of the sound attenuator
H Height of the sound attenuator and the splitters
Installation with the splitters lying flat only for splitters up to height 1200 mm

Upstream conditions after bends, junctions or a narrowing or widening of the duct, horizontal upstream section, splitters upright

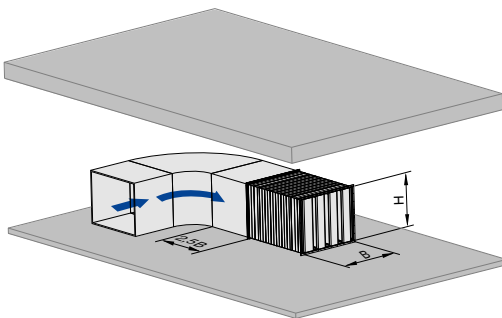

B Width of the sound attenuator
H Height of the sound attenuator and the splitters

Upstream conditions after bends, junctions or a narrowing or widening of the duct, horizontal upstream section, splitters lying flat

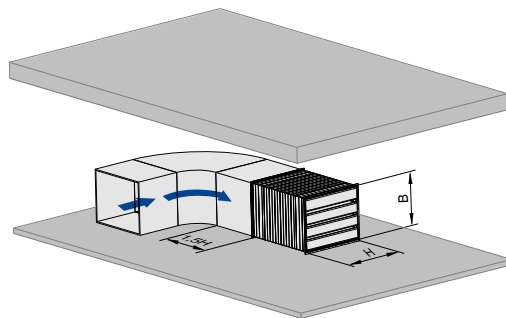

B Width of the sound attenuator
H Height of the sound attenuator and the splitters
Installation with the splitters lying flat only for splitters up to height 1200 mm

{249}

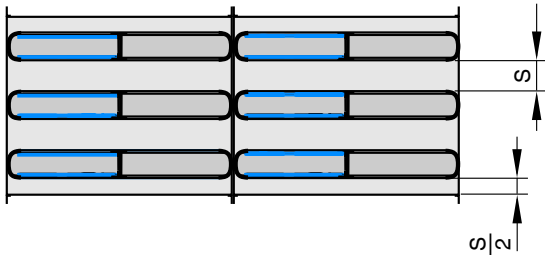

{249}

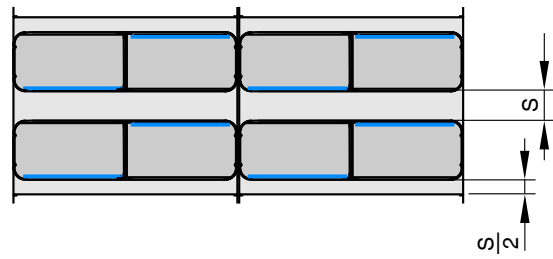

MK100: Opposite resonating panels

MK200, MK230: Offset resonating panels

Accessories – variant ACC

- U-sheets/clamp sheets to join subdivided attenuator splitters (included with subdivided splitter constructions)
- U-sheets and clamping sheets (ACC) for previously provided single splitters that are to be connected
 - Made of galvanised sheet steel 1.0917 or stainless steel 1.4301
 - Number according to division rule for height or length subdivided splitters
 - Specification of the total dimensions is necessary for the delivery of the recommended number of pieces
- Fixing material for connecting the U-sheets and clamp sheets to the sound attenuator to be provided by others

Number of clamp sheets per splitter joint:

H or L ≤ 750 mm: without clamp sheet

H or L 751 – 1000 mm: 1 clamp sheet on each side

H or L > 1000 mm: 2 clamp sheets on each side recommended

Number of U-sheets per splitter joint: 2

Follow the instructions in the installation manual.

{249}

A

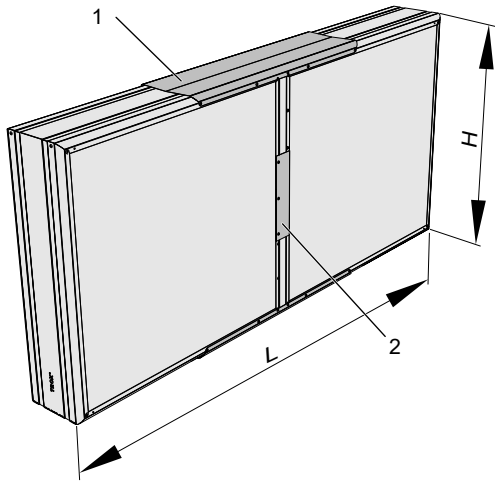

B

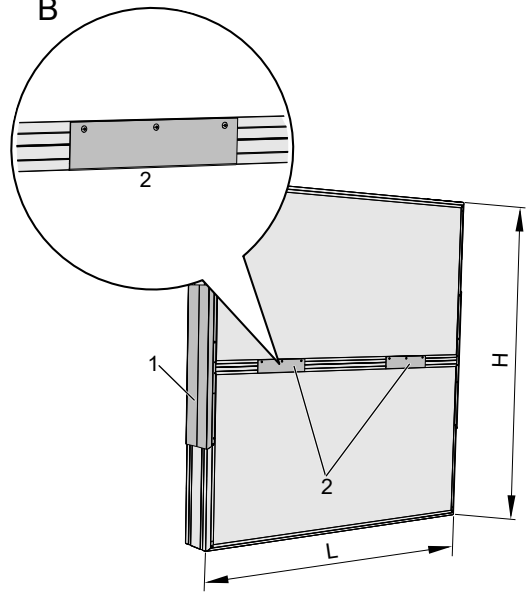

A Construction with length subdivided

- H 1000 × L 4000 with 2 U-sheets, 2 clamp sheets

B Height subdivided

- H 2000 × L 2500 with 2 U-sheets, 4 clamp sheets

{249}

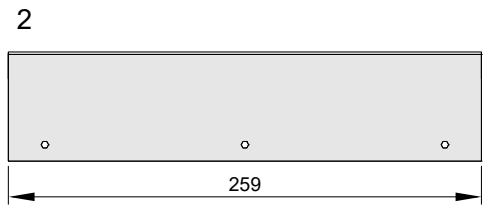
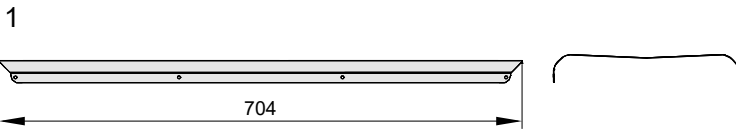

1 U-sheet

2 Clamp sheet

Explanation

L [mm]

Length of sound attenuator including spigot (always in airflow direction)

L₁ [mm]

Length of part 1 of a splitter sound attenuator with the length subdivided

L₂ [mm]

Length of part 2 of a splitter sound attenuator with the length subdivided

B [mm]

Sound attenuator width and duct width

B₁ [mm]

Width of part 1 of a splitter sound attenuator with the width subdivided

B₂ [mm]

Width of part 2 of a splitter sound attenuator with the width subdivided

H [mm]

Sound attenuator height and duct height (upright splitters)

T [mm]

Splitter thickness

S [mm]

Airway width

m [kg]

Weight

f_m [Hz]

Octave band centre frequency

D_e [dB]

Insertion loss

q_v [m³/h]; [l/s]

Volume flow rate

Δp_t [Pa]

Total differential pressure

v_s [m/s]

Airflow velocity

Lengths

All lengths are given in millimetres [mm] unless stated otherwise.

Measured values

All sound power levels are based on 1 pW. All values were measured in a TROX lab and to EN ISO 7235. Intermediate values may be achieved by interpolation. Lab measurements exceeding 50 dB are given as 50 dB, based on practical conditions.